



# **A research for improvement of quick transportability, time reliability and safety of Advanced Rapid Transit**

**November 16, 2016**

**Daisuke Oshima**

**Pacific  
Consultants**

Producing  
The Future™

P R O D U C I N G  
T H E F U T U R E

# Contents

- Objective
- Current PTPS in Japan
- Summary of Advanced PTPS
- Evaluation of Advanced PTPS using traffic simulation
- Experiment in a test site

PRODUCING  
THE FUTURE  
PRODUCING  
THE FUTURE  
PRODUCING  
THE FUTURE  
PRODUCING  
THE FUTURE  
PRODUCING  
THE FUTURE

# Objective

- To increase a utilization of bus services, ensuring **the speed and the time reliability** of bus services is one of the important factors.
- But it is not easy because a bus runs with general traffic is **affected by traffic disorder**.

Advanced PTPS(Public Transportation Priority System)  
\*Rapid and On-time operation

Advanced operation system with automated control systems  
\*Seamless and stress free connection

Automated acceleration control  
\*Smooth & Comfortable ride

Automated pull-over control  
\*Accessibility  
\*Short time and Safety boarding

Advanced Driver Assistance  
\*Traffic accidents prevention  
\*Driver burden reduction

Universal built-in seats  
Contactless electronic charging  
\*Cabin Safety and Convenience

Cooperative ACC  
\*Traffic congestion/CO2 reduction

Cyber Agent

Cross-ministerial Strategic Innovation promotion Program (SIP)

# Current PTPS in Japan

- Optical Beacon is installed on the upstream side of a signalized intersection and it detects arrival of buses.
- Traffic signal is controlled based on the bus detection information by the beacon.

## Green extension, Red reduction or Green reduction

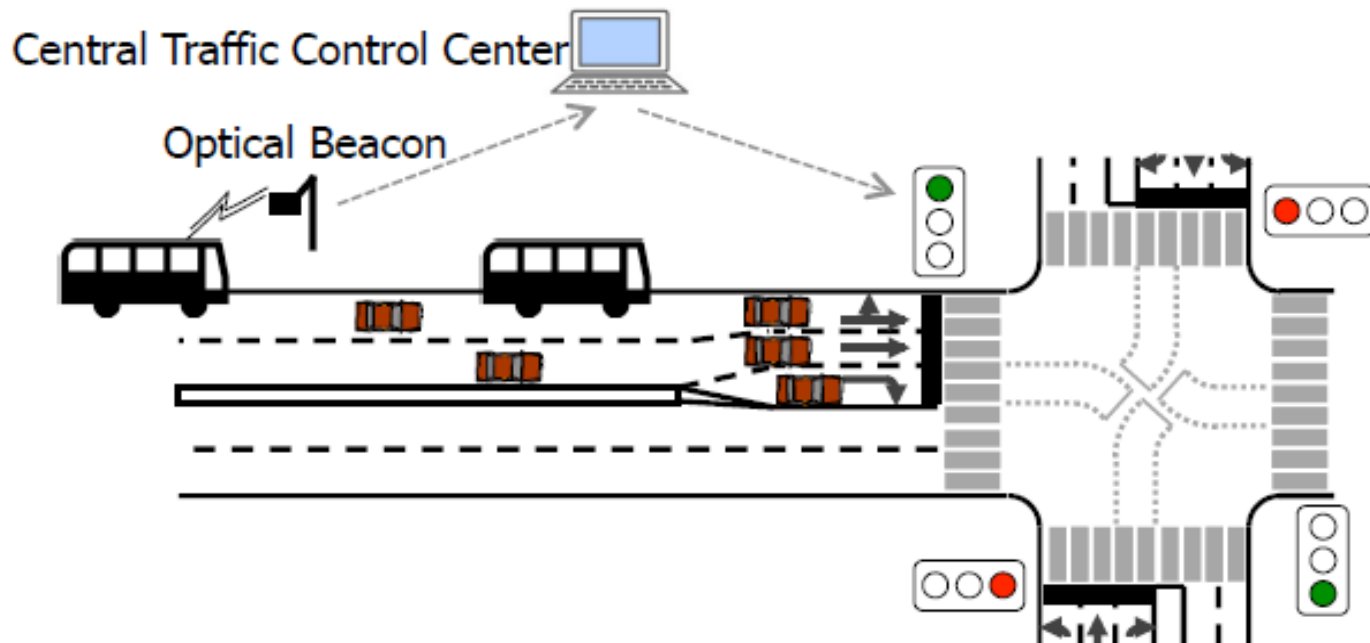

# Current PTPS in Japan

## ■ Green extension

If a bus arrival time at signalized intersection is expected as during the first part of red indication, the previous green time is extended so that the bus can pass through without stopping at red signal.

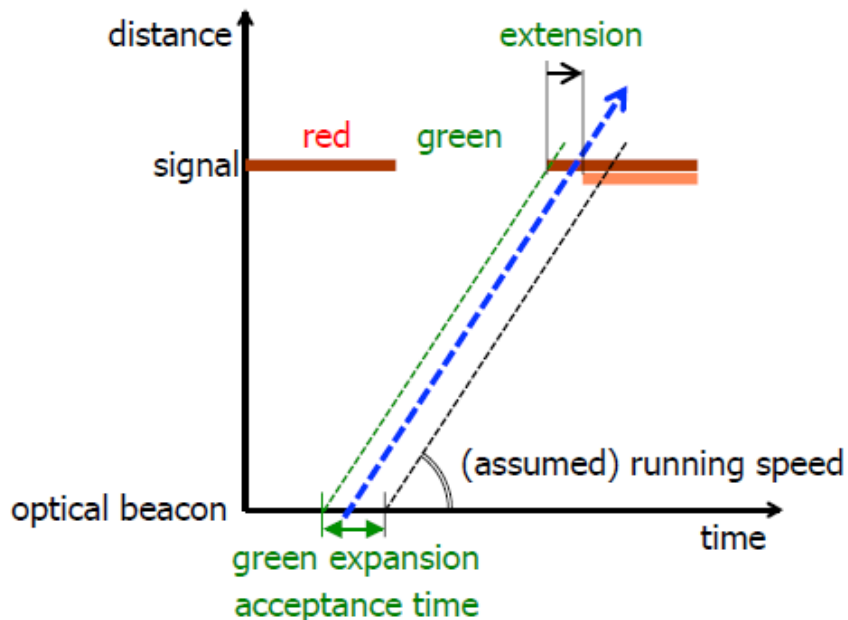

## ■ Red reduction

If a bus arrival time at signalized intersection is expected as during the last part of red indication, the red time is reduced so that bus can pass through without stopping at red signal.

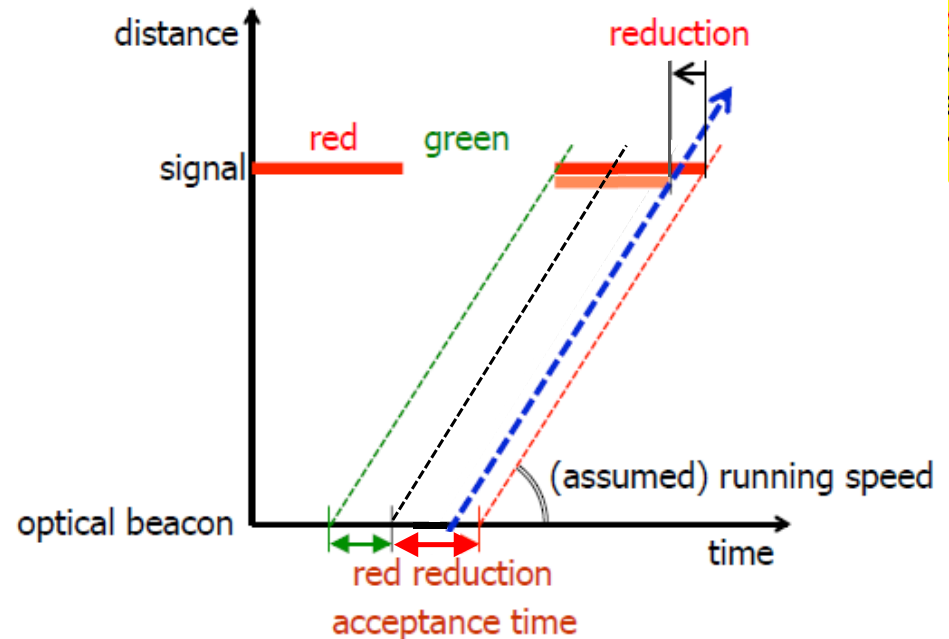

## Possibilities to increase the efficiency of current PTPS

---

- Traffic signal is controlled based on the bus detection information only at one upstream point of an intersection.
  - **Traffic disturbance (parking, cut-ahead-in)** may affect
- Only the signal timing can change.
  - Limited application of **dedicated lane** and **dedicated traffic signal for bus**
- The information related to priority status does not provide to bus drivers.

# Summary of Advanced PTPS

Advanced PTPS can keep communication with running ART and send message to ART drivers using 700MHz band vehicle-to-infrastructure communication.

- Advanced PTPS detects approaching ART twice before ART arrives at an intersection and control the signal timing.
- It can also detects the intersection passage of ART.
- The state of priority provides to ART as downlink information and can support appropriate acceleration and deceleration for ART drivers.

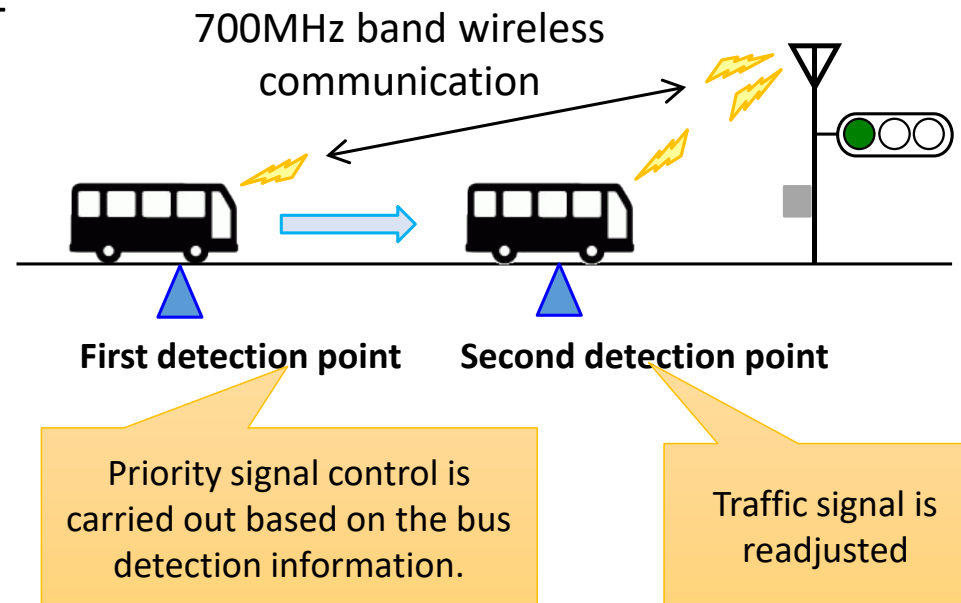

# Simulation study

- To evaluate the effect of introduction of Advanced PTPS, a simulation study was conducted with the following four cases.

Case	Traffic signal control	Dedicated lane	Heavy congestion around the intersection
0 (Base case)	without PTPS	No	No
1	Advanced PTPS	No	No
2	Advanced PTPS	No	Yes
3	Advanced PTPS	Yes(both sides)	Yes

- ART is generated at 6 minute intervals.  
(the simulation time is 1 hour, 10 ART in total)
- Evaluation indexes
  - ✓ Travel time and delay of ART
  - ✓ Throughput of the signalize intersections including general vehicles



# Simulation case

## Case 1 & 2 : Advanced PTPS only

Advanced PTPS detects ART at 200m and 100m upstream of a signalized intersection and controls the signal timing.

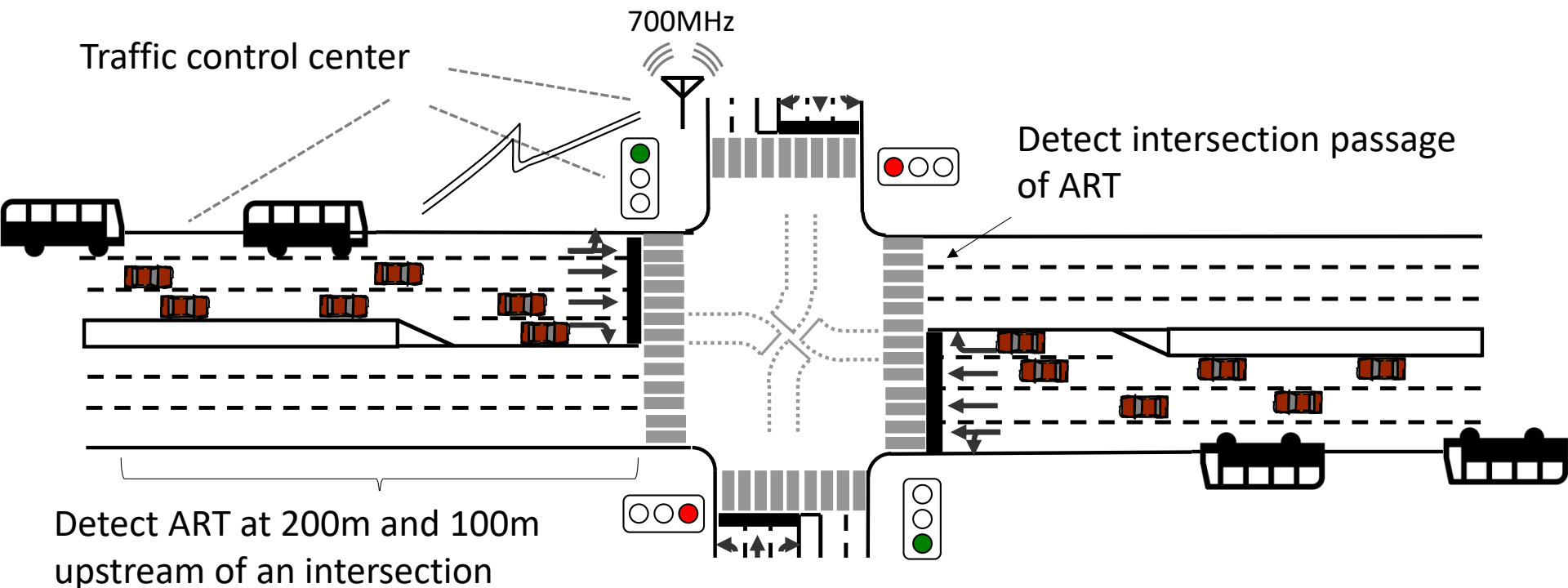

# Simulation case

## Case 3 : Advanced PTPS & Dedicated lane for ART (both sides of the road)

In addition to Advanced PTPS, Dedicated lane for ART along both sides of the road is introduced.

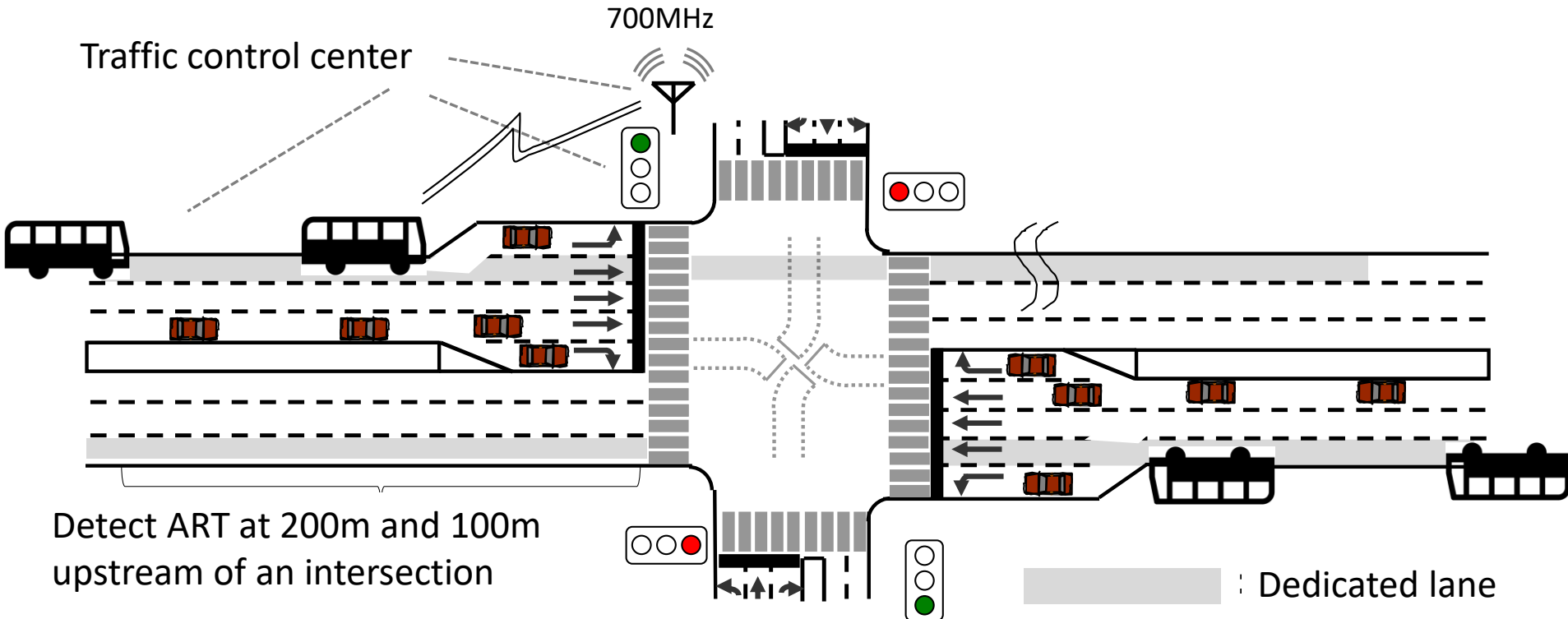

# Simulation network

## Tokyo Ring Road #2

- Tokyo Ring Road #2 was selected for the simulation network.
- Introduction of new bus service is planned on the ring road by Tokyo Metropolitan Government.

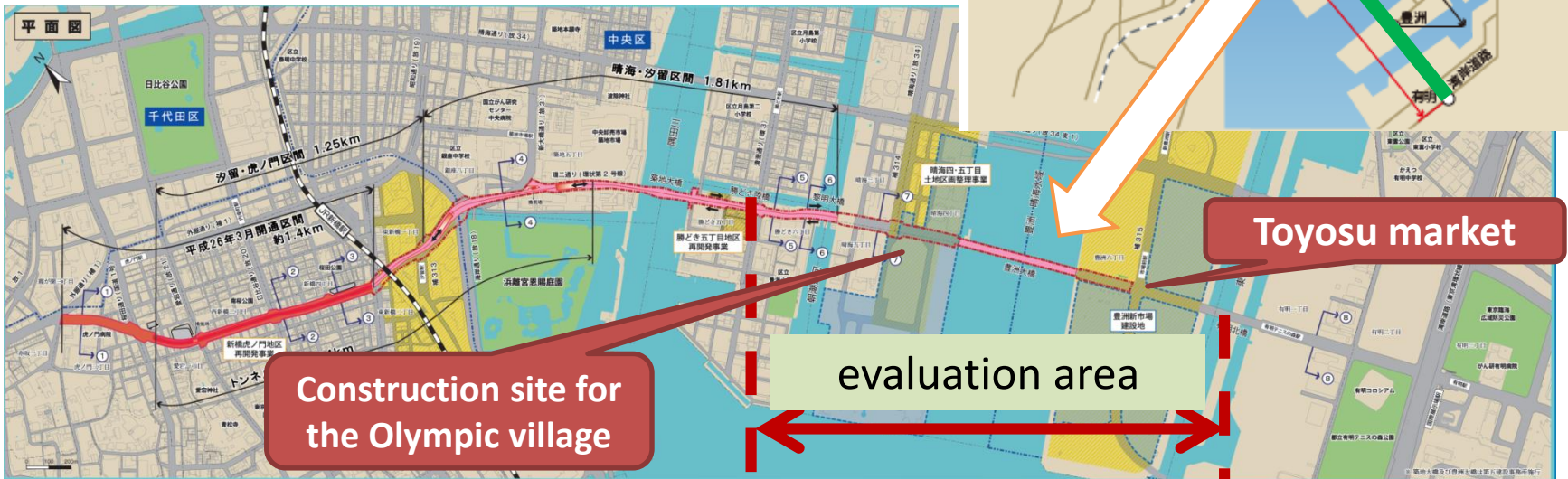

Source: Tokyo Metropolitan Government

## Results of the simulation study (average travel time)

- Advanced PTPS has possibility to shorten the average travel time of ART.
- It may not be able to obtain the sufficient effect of Advanced PTPS by traffic disturbances.
  - Dedicated lane may be necessary

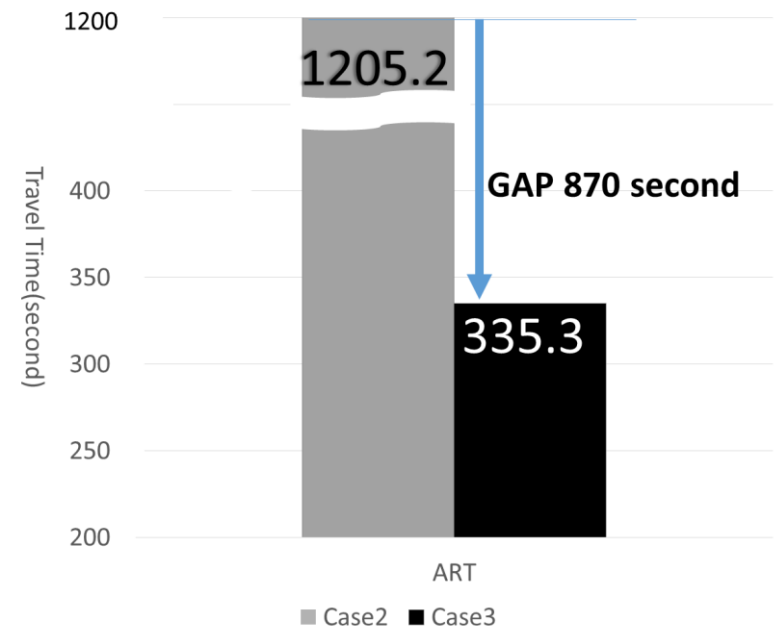
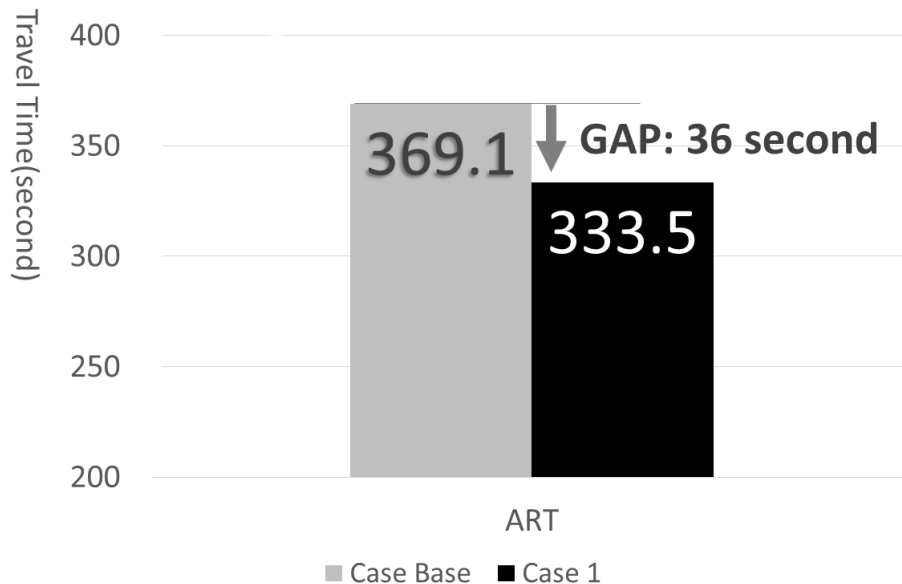

## Results of the simulation study (delay)

- The occurrence of delay by the signalized intersections for more than 100 seconds decreased by introducing Advanced PTPS.
  - potential to contribute improvement of **an operation diagram**

	Base Case	Case 1	Case 2	Case 3
1 <sup>st</sup>	157	125.2	246.8	118.4
2 <sup>nd</sup>	23.2	102	385.8	31
3 <sup>rd</sup>	178.4	82	457.6	62.8
4 <sup>th</sup>	35.8	22	378	55.6
5 <sup>th</sup>	9.4	93.8	492.2	59.4
6 <sup>th</sup>	136.6	79.2	87.6	0
7 <sup>th</sup>	123.2	19	318	31.2
8 <sup>th</sup>	166.6	0	88.2	122.4
9 <sup>th</sup>	36.6	50.2	357	85.6
10 <sup>th</sup>	2.8	22.6	0	0
Total	869.6	596	2811.2	566.4
Average	86.96	59.6	281.12	56.64
Max.	178.4	125.2	492.2	122.4
S.D.	67.6	40.3	160.6	40.9

# Simulation case

Future work

**Case3 : Advanced PTPS & Dedicated lane (center of the road) and traffic signal for ART**

Dedicated lane center of road and Dedicated signal for ART are introduced.

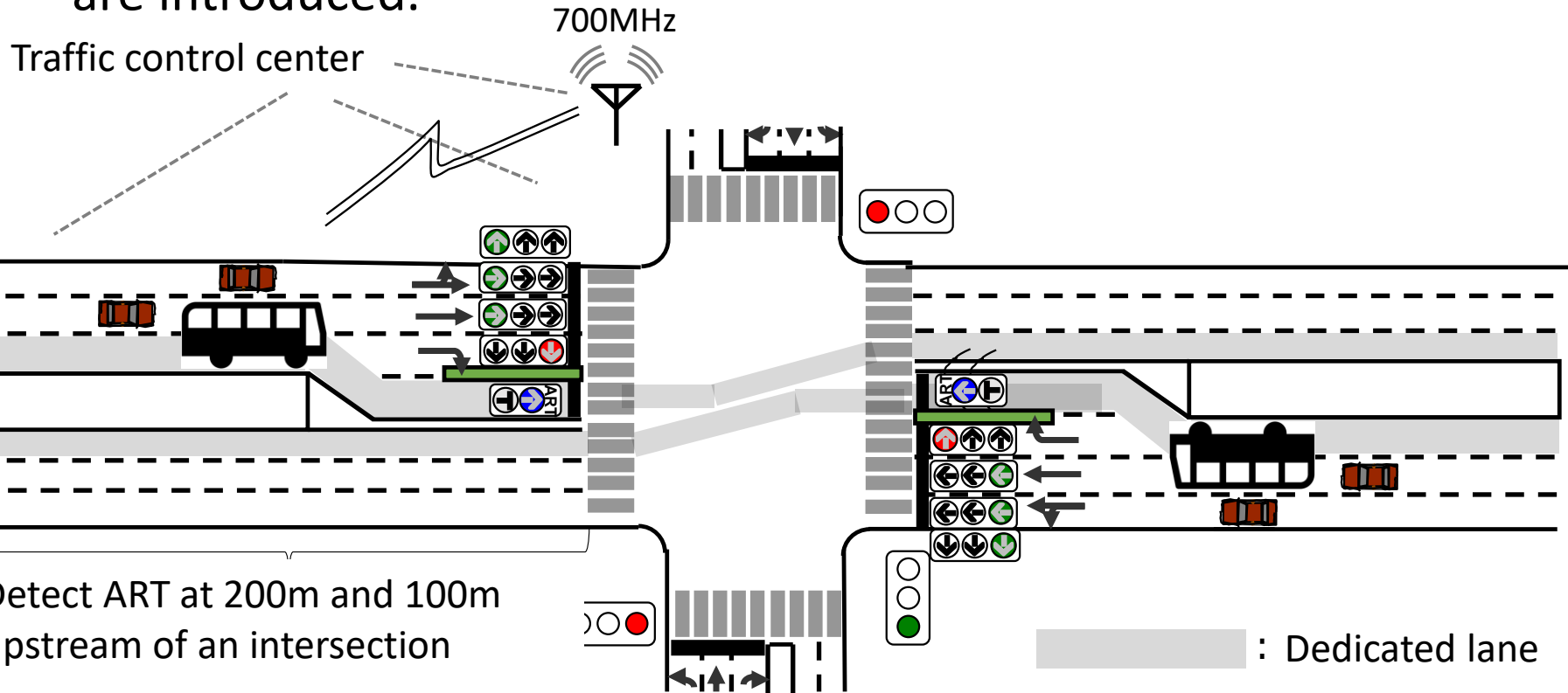

# Machine verification in a test site

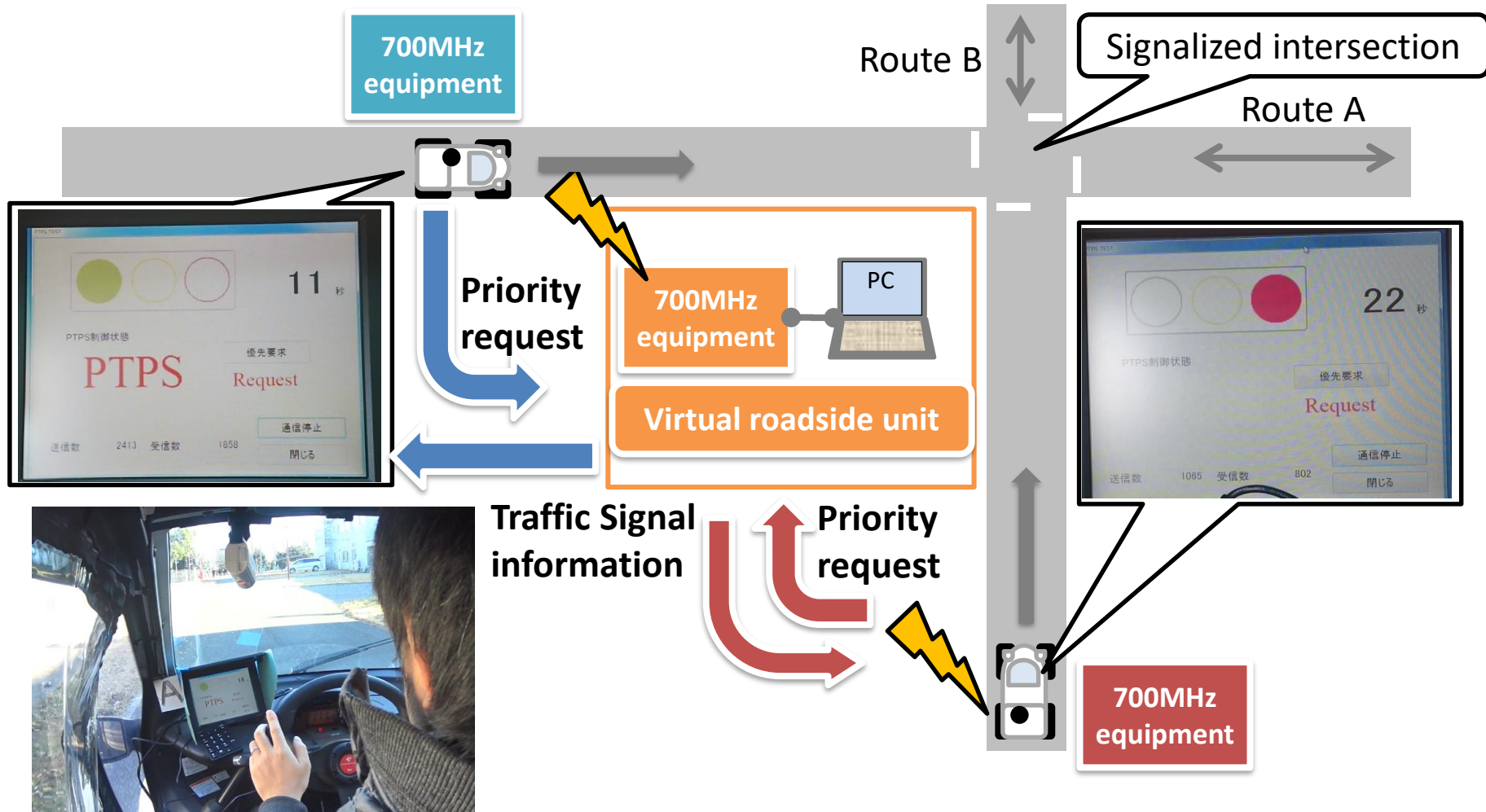

- Objective
- Current PTPS in Japan
- Summary of Advanced PTPS
- Evaluation of Advanced PTPS using traffic simulation
- Experiment in a test site



**Thank you for your kind attention.**

**Contact**

Daisuke Oshima

[daisuke.ooshima@ss.pacific.co.jp](mailto:daisuke.ooshima@ss.pacific.co.jp)

 Pacific Consultants

PRODUCING  
THE FUTURE  
PRODUCING  
THE FUTURE  
PRODUCING  
THE FUTURE  
PRODUCING  
THE FUTURE  
PRODUCING  
THE FUTURE

# Requirements rearranging of on-board equipment

■ Requirements of on-board equipment for advanced PTPS

Requirements related to communication	<ul style="list-style-type: none"> <li>• Transmission of the uplink information of own car state such as vehicle location or vehicle speed and PTPS priority request</li> <li>• Reception of the downlink information of PTPS service and signal information</li> </ul>
Requirements about situation grasping and judgment	<ul style="list-style-type: none"> <li>• Acquisition of intersection shape and virtual beacon position and service in / service end judgement</li> <li>• Grasp of operating conditions in connection with bus location systems</li> <li>• Grasp of operational status of PTPS priority signal control based on a change of the signal information</li> <li>• Calculation of the determining passage through intersection and target deceleration in the green light time</li> <li>• Calculations of the effect by the service</li> </ul>
Requirements about the notice to a driver	<ul style="list-style-type: none"> <li>• Notice of service in, service end and state of PTPS priority signal control</li> <li>• Notices of the deceleration support</li> </ul>

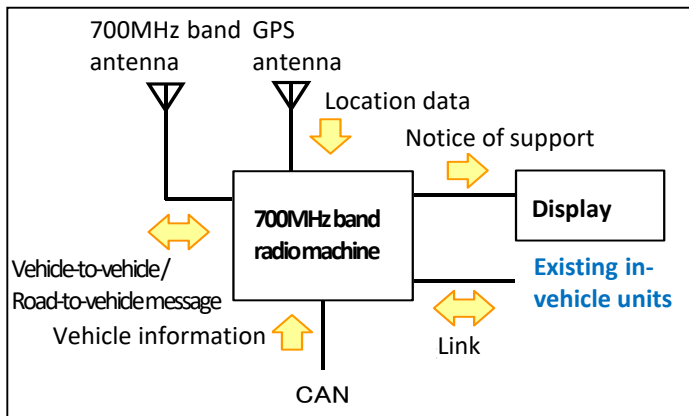

- Transmitting and receiving information by 700MHz band radio machine (can be shared by things for DSSS)
- Grasping an own car state based on the information from GPS and CAN
- Acquiring information from an existing bus location systems or fare system and judge the priority request if necessary.(big change is unnecessary for specifications of the existing equipment side)
- Using HMI such as displays, appropriate information is provided for a driver

# Result of a real machine verification

